



## Gate, Globe and Check Valves





## COMPANY OVERVIEW

Notash Sanat Company is located in the Tehran, Iran. Since its establishment Notash has purchasing its own cast and forged valves. Our experience of over 20 years on the valve, Pipe and fitting industry is the key to our international success and recognition.

in the valve industry Our company activities include the Purchasing, material procurement, Delivery and thesting of valves. We supply Gate, Globe, Check, Ball Plug, Butterfly, Control and Special Valves produced according to different standards (ASME-ANSI, DIN, API, BS), sizes, pressure ratings and materials (Carbon Steel, Alloy Steel, Stainless Steel, Duplex, Monel, etc.).

Our valves are used in many different applications such as Oil & Gas, chemical and Petrochemical, Cryogenic and Power Generation (including Nuclear , Combined Cycle, Thermoelectric and Hydraulic Plants).

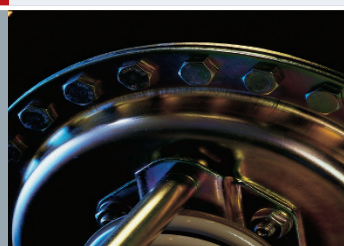



## CONTENTS

- 01 Gate Valves. Pag. 8
- 02 Globe Valves. Pag. 10
- 03 Check Valves. Pag. 12
- 04 Valve Materials. Pag. 14
- 05 General Valve Features. Pag. 16
- 06 Gate Valve Dimensions. Pag. 18
- 07 Globe Valve Dimensions. Pag. 21
- 08 Check Valve Dimensions. Pag. 23
- 09 Gate API 6A Valve Dimensions. Pag. 26
- 10 Check API 6A Valve Dimensions. Pag. 27
- 11 Manufacturing Range. Pag. 28



# 01. GATE VALVES

Our gate valves program includes:

- Standard gate valves: solid wedge, flexible wedge and split wedge.
- Parallel slide gate valves.
- Through conduit gate valves to API 6D and API 6A.
- Single and double expanding gate valves.
- Bolted bonnet, pressure seal and cryogenic designs are available.

Standards	Sizes	Features Design - Materials
ANSI B16.34 API 600 API 6D BS - 1414	- 72" ANSI 150 - 64" ANSI 300 - 48" ANSI 600/900 - 36" ANSI 1500/2500 - 24" ANSI 4500	Bolted bonnet Pressure seal Cast and forged Solid Wedge Flexible Split Wedge
API 6A	2-1/16" to 7-1/16" class 2000 2-1/16" to 7-1/16" class 3000 2-1/16" to 9" class 5000 1-13/16" to 7-1/16" class 10000 1-13/16" to 5-1/8" class 15000	Parallel Slide Through conduit Special Designs Double Block and Bleed

Gate valves are designed to meet requirements of ANSI B16.34, API 600, API 6D ANSI B16.5, ANSI B16.10, API 602 and API 6A.

For nuclear service ASME III, AD-Mekblatter and RCC-M are available.



## ■ Wedge Gate Valves

### Solid Wedge Design:

The wedge is made in one solid piece being the downstream side the one which seals the valve when upstream pressure push the wedge against the downstream seat.

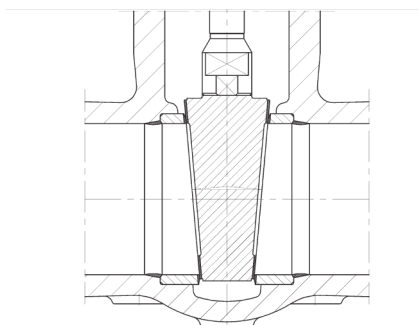

### Flexible Wedge Design

The wedge has a machined groove in its central part providing flexibility at the disc.

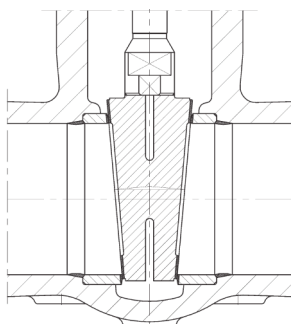

### Split Wedge Design

The wedge is made in two separate parts providing high ability to seal. This design is recommended when high thermal or mechanical deformations are expected due to working conditions.

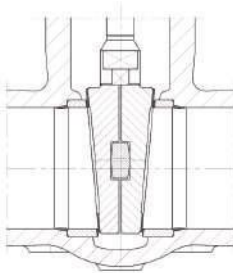

## ■ Parallel Gate Valves

### Parallel Slide Gate Valves

For those applications when large temperature variations are expected or fast shut-off is required, this is the most ideal design. The seats are parallel and the disc has no contact with the seats during the stroke of the valve. Only at the end of the stroke the disc mechanism ensures the contact between seats and disc.

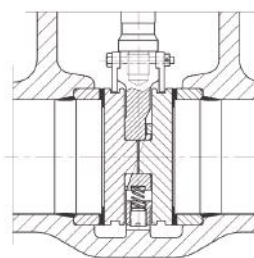

### Through Conduit

When full port gate valve is required or double block and bleed valve is mandatory this design must be used. Through conduit gate valves are designed to API 6D or API 6A.

Seats are floating and sealing is made by the upstream seat which is energized by upstream pressure against the disc. These valves are pigable and normally used for oil and gas application. Both, soft seated and metal seated valves are available.

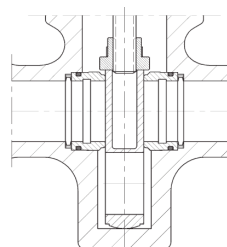

### Double Expanding Gate

Metal to Metal seated, double block and bleed are available to API 6D & API 6A.

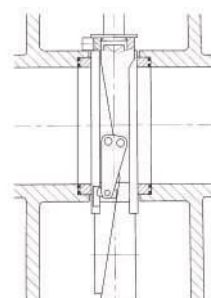

## 02. GLOBE VALVES

Our globe valves program includes:

- Straight pattern globe valves.
- Y-pattern globe valves.
- Angle (90°) globe valves.
- Stop check globe valves.
- Positive and adjustable chokes to API 6A.
- Globe control valves.
- Extended bonnet for cryogenic services.

In all cases globe valves can be provided for ON/OFF services as well as for throttling or control applications.

Standards	Sizes	Features Design - Materials
ANSI B16-34 BS - 1873	- 48" ANSI 150/300 - 36" ANSI 600/900 - 24" ANSI 1500/2500 - 12" ANSI 4500	Bolted Bonnet Pressure seal Cast and forged Zero steam leakage Non return "Y" pattern globe Bellows seal globe Stop check globe Angle globe valve

Globe valves are designed to meet requirements of ANSI B16.34, BS-1873, ANSI B16.5, ANSI B16.10 and API 602.

For nuclear service ASME III, AD-Mekblatter and RCC-M are available.

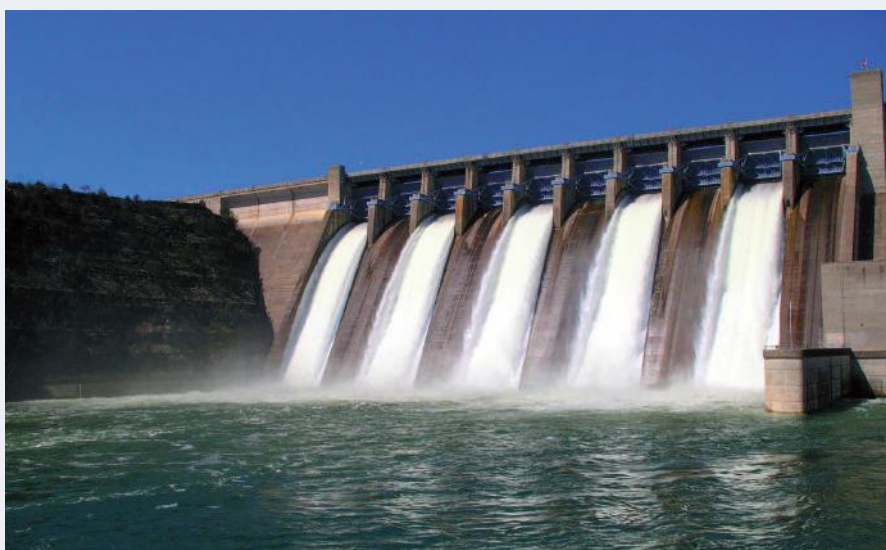

## ■ Globe Valves Configurations

### Straight Pattern

This is the most commonly used design (standard T-Pattern), providing large pressure drop across the valve.

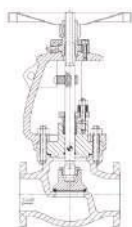

### Y-Pattern

When lower pressure drop across the valve is required Y-Pattern is recommended.

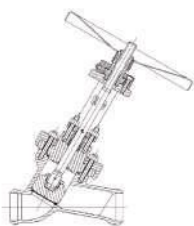

### Angle (90°)-Pattern

This design is used when two perpendicular pipes must be connected.

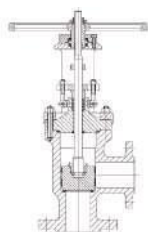

### Cage Guided

In those cases when valve is intended for control or throttling service, cage guided design is required. There are different types of cages and trims designed to provide different valve characteristics and Cv-values.

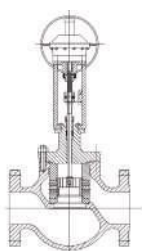

## ■ Special Globe Valves

### Choke Valves

For API 6A applications choke valves, both positive and adjustable are available. Choke valves are specifically design for service conditions providing different types of beans for positive chokes (including ceramic materials, tungstem carbide and hardened mar-tensitic steels) as well as different configurations of seats, cages and discs for adjustable chokes.

### Stop Check Valves

This design is a combination between globe valve and check valve. When valve is open, the stem is in open position the valve operates like a piston check valve, disc is moved by the fluid-media. However when valve has to be closed the stem goes down against the disc ensuring shut-off of the valve.

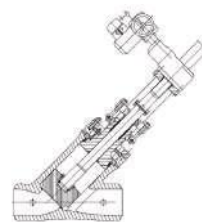

### Bellows-Sealed Valves (Zero Stem Leakage)

For those applications when emissions to the atmosphere are strictly forbidden, valve is provided with metallic bellows which ensures no leakage through the stem packing to the atmosphere.

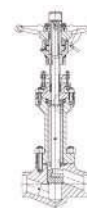

### Control Valves

RV offers a wide range of control valves for the most severe applications.

In those cases when valve is intended for control or throttling service, cage guided design is required. There are different types of cages and trims designed to provide different valve characteristics and Cv-values.



## 03. CHECK VALVES

Our program for check valves includes:

- Swing check valves.
- Piston check valves.
- Dual plate check valves.
- Butterfly check valves.
- Emergency assisted check valves.
- Testable check valves.
- Tilting disc check valves.

Standards	Sizes	Features Design - Materials
API 6D BS - 1868 ANSI B16-34	- 64" ANSI 150/300 - 48" ANSI 600/900 - 36" ANSI 1500/2500 - 24" ANSI 4500	Bolted bonnet Pressure seal Cast and forged Piston check
API 6A	2-1/16" to 11" class 2000 2-1/16" to 11" class 3000 2-1/16" to 9" class 5000 1-13/16" to 7-1/16" class 10000 1-13/16" to 4-1/8" class 15000	Tilting disc Swing check Emergency assisted Duo Check

Check valves are designed to meet requirements of ANSI B16.34, BS-1868, ANSI B16.5, ANSI B16.10, API 602, API 6D and/or API 6A.

For nuclear service ASME III, AD-Mekblatter and RCC-M are available.





### Swing Check Valves

Valve disc is provided with antirotations pin. Full opening swing check valves to API 6D or API 6A suitable for pig passage are also available.

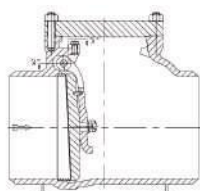

### Piston Check Valves

Normally upto sizes 2", (larger sizes are also available) both T-Pattern and Y-Pattern are available.

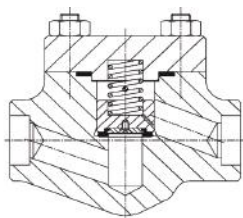

### Dual Plate Check Valves

Valves provided with double disc and spring. They are available with metal to metal seats and soft seats. This design reduces substantially the weight of the valve as well as the face to face dimension.

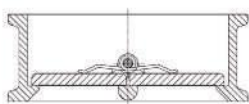

### Tilting Disc Check Valves

When the check valve must be operated by a very small pressure drop this design is used. Valve disc is balanced in such a way that very small variations of pressure open/close the valve. This reduces substantially the pressure drop across the valve.

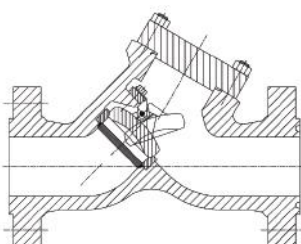

### Emergency Assisted Check Valves

Used in the turbine steam extractions of power plants. Valve is provided with a pneumatic piston and solenoid valve in such a way that when a closing signal is received in the solenoid valve the air in the pneumatic piston is released starting the closing stroke of valve disc and ensuring fast valve closing by fluid-media.

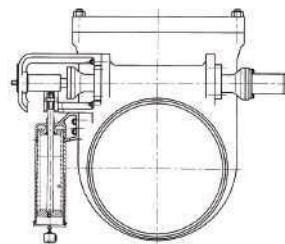

### Testable Check Valves

In those cases when indication of check valve position is required the valve is provided with a position indicator and limit switches. Also a operating lever is available in case proper rotation of hinge shaft must be checked.

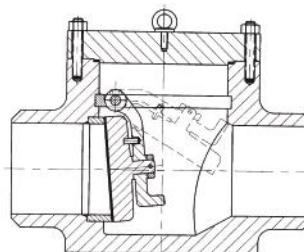

### Butterfly Check Valves

Normally used in the outlet of large size pumps or inlet of hydro power plant turbines. Valve can operate like a butterfly valve but also like a check valve by fluid-media.

## 04. VALVE MATERIALS

Carbon Steel for General Use	WCB, WCC, WCA... A 105N...
Carbon Steel for Low Temperature	LCB, LCC, LCA, LC3... LF2, LF3, LF6...
Alloy Steel for High Temperature	WC1, WC6, WC9, C5, C12, C12A... F1, F11, F22, F5, F9, F91...
Martensitic Steel	CA15, CA6NM... F6
Stainless Steel Corrosion Resistant	CF8, CF8M, CF3, CF3M, CF8C... F304, F316, F304L, F316L, F321, F347...
Duplex & Superduplex Stainless Steel	CD4MCu, CD4MCuN, CK3MCuN... F51, F44, F52, F53...
Nickel Base Alloys	Inconel 625, Hastelloy (CW-12MW), Incoloy 825, Monel...

(\* ) Table based on ASTM materials. Equivalent DIN materials are also available upon request.



## Trim Materials

Different combinations of trim material consistent with body / bonnet material according API 600 are available.

Different hard facings for sealing areas can be used being the most common ones: stellite-6 & 12, 13% Cr, Bohler skwan, Cobalt free alloys, and Tungsten Carbide for API 6A applications.

Different hardened martensitic steels upto 48 HRC are also available for globe valves wearing resistant trims.

### NOMINAL SEATING SURFACE, STEM AND BACKSEAT BUSHING OR WELD-DEPOSIT MATERIALS AND HARDNESS

Trim Number	Nominal Trim	Seat Surface Typical Specifications Grade			Stem/Bushing
		Cast	Forged	Welded <sup>m</sup>	Material Type <sup>h</sup>
1	F6	ASTM A217 (CA15)	ASTM A105 (F6A)	AWS A5.9 ER410	13Cr
2	304	ASTM A351 (CF8)	ASTM A182 (F304)	AWS A5.9 ER308	18Cr-8Ni
3	F310	NA	ASTM A182 (F310)	AWS A5.9 ER410	25Cr-20Ni
4	Hard F6	NA	Note <sup>h</sup>	NA	13Cr
5	Hardfaced	NA	NA	AWS A5.13 ER or R CoCra	13Cr
5A	Hardfaced	NA	NA	Note <sup>h</sup>	13Cr
6	F6 and CU-Ni	ASTM A217 (CA 15) NA	ASTM A182 (F6A) Note <sup>h</sup>	AWS A5.9 ER410 NA	13Cr NA
7	F6 and Hardfaced F6	ASTM A217 (CA 15) NA	ASTM A182 (F6A) Note <sup>h</sup>	AWS A5.9 ER410 NA	13Cr NA
8	F6 and Hardfaced	ASTM A217 (CA 15) NA	ASTM A182 (F6A) NA	AWS A5.9 ER410, AWS A5.13 E or R CoCra	NA
8A	F6 and Hardfaced	ASTM A217 (CA 15) NA	ASTM A182 (F6A) NA	AWS A5.9 ER410 Note <sup>h</sup>	13Cr NA
9	Monel	NA	MFG Standard	NA	Ni-Cu Alloy
10	316	ASTM A351 (CF8M)	ASTM A182 (F316)	AWS A5.9 ER410	18Cr-8Ni-Mo
11	Monel and Hardfaced	NA	MFG Standard	NA See Trim 5 or 5A	Ni-Cu Alloy NA
12	316 and Hardfaced	ASTM A351 (CF8M)	ASTM A182 (F316)	AWS A5.9 ER316 See Trim 5 or 5A	18Cr.8Ni-Mo NA
13	Alloy 20	ASTM A351 (CN7M)	ASTM B473	AWS A5.9 ER320	19Cr-29Ni
14	Alloy 20 and Hardfaced	ASTM A351 (CN7M) NA	ASTM B473 NA	AWS A5.9 ER320 See Trim 5 or 5A	19Cr-29Ni
15	Hardfaced	NA	NA	AWS A5.13 E or R CoCra	18Cr-8Ni
16	Hardfaced	NA	NA	AWS A5.13 E or R CoCra	18Cr-8Ni-Mo
17	Hardfaced	NA	NA	AWS A5.13 E or R CoCra	18Cr-10Ni-Cb
18	Hardfaced	NA	NA	AWS A5.13 E or R CoCra	19Cr-29Ni

## Soft Seated Valves

For cryogenic or other special applications soft seated valves are also available.

## 05. GENERAL VALVE FEATURES

### Bolted Bonnet Pressure Seal & Welded Bonnet

Body-Bonnet construction can be either bolted bonnet, pressure seal or welded bonnet. Bolted bonnet is normally applicable for low-medium pressure (up to 600#). For larger pressures 900# and above both pressure seal and bolted bonnet can be used.

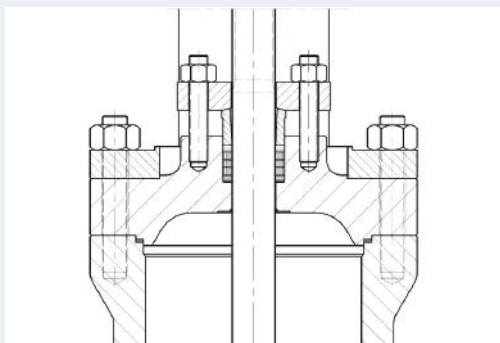



Pressure seal design reduces the weight of valve since it avoids large diameter body-bonnet connection flange and large size body-bonnet bolting. Welded bonnet design is only used for small sizes up to 2".

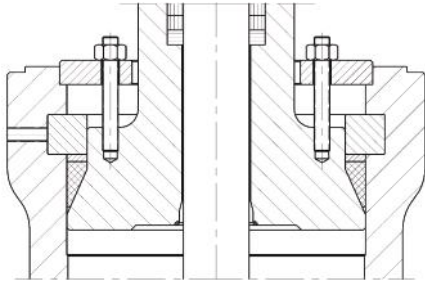

### Stuffing Box & Packing

Gate valves are provided with graphite, PTFE etc packing which avoids leakage through stem area to the atmosphere.

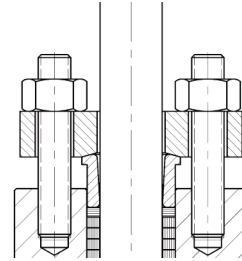

### OS & Y Construction

All designs of gate valves are normally with OS & Y (outside screw & yoke construction). Valve is provided with yoke which allows access to the valve stem.

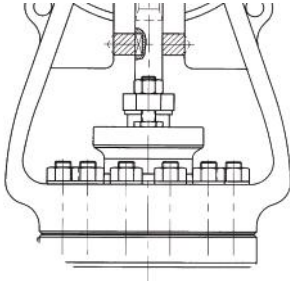

### Leak-Off & Packing Expulsor

When leakage through packing must be prevented, valve is provided with leak-off which provides indication of leakage through packing.

In those cases when packing must be replaced quickly, packing expulsor can be provided for immediate replacement.

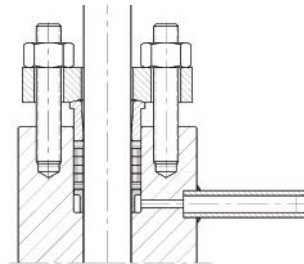

### Back Seat

Gate and globe valves are provided with back seat which allows to change valve packing in the valve when the valve is under pressure.

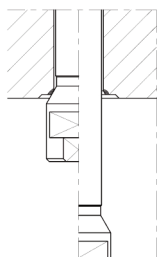

### Handwheel Operated, Gear Operated and Motor Operated Valves

RV gate valves can be provided manually operated both by direct hand-wheel and gear box or with automatic operation by electric, pneumatic or hydraulic actuators.

## 06. GATE VALVE DIMENSIONS API 600 / ANSI B16, API 6D

### ■ Class 150

SIZE	FACE TO FACE (A)			H	L	K	CV	Approx. Weight RF (Kg.)
	RF	RTJ	BW					
2"	178	191	216	296	261	-	200	16
3"	203	216	282	533	457	-	710	40
4"	229	241	305	645	538	-	1300	52
6"	267	279	403	850	693	-	3100	90
8"	292	305	419	1079	863	-	5720	145
10"	330	343	457	1308	1036	-	8940	225
12"	356	368	502	1447	1130	-	13350	310
14"	381	394	572	1651	1272	-	16275	445
16"	406	419	610	1879	1447	-	21560	540
18"	432	444	660	2184	1701	-	28720	800
20"	457	470	711	2431	1795	-	35760	990
24"	508	521	813	2837	2189	-	52165	1600
26"	559	-	864	3086	2387	-	63500	1850
28"	610	-	914	3327	2590	-	74800	2100
30"	610	-	914	3606	2819	-	86235	2700
32"	610	-	965	3708	2870	-	103000	3100
36"	711	-	1016	3924	2997	-	129500	3950
40"	812	-	1066	4318	3302	-	175860	4650
42"	812	-	1143	4546	3479	-	223300	5100
48"	1066	-	1371	5181	3962	-	335500	6500

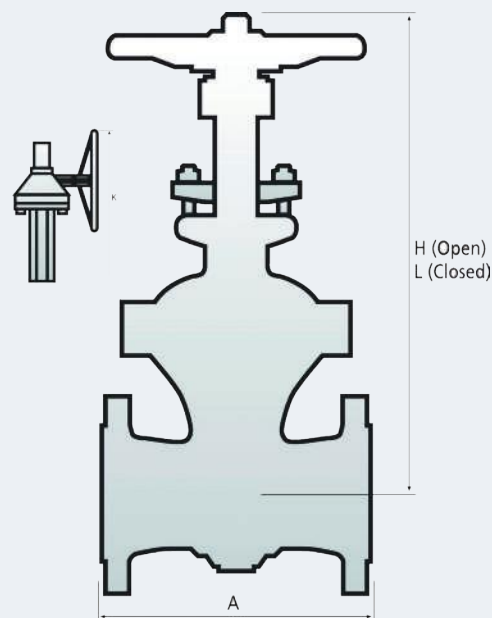

### ■ Class 300

SIZE	FACE TO FACE (A)			H	L	K	CV	Approx. Weight RF (Kg.)
	RF	RTJ	BW					
2"	216	232	216	312	277	-	200	18
3"	282	298	282	596	520	-	710	52
4"	305	321	305	716	609	-	1300	85
6"	403	419	403	984	825	-	3100	150
8"	419	435	419	1219	1009	-	5720	240
10"	457	473	457	1460	1193	-	8940	380
12"	502	518	502	1600	1282	-	13350	430
14"	762	778	762	1790	1422	-	16275	730
16"	838	854	838	1968	1549	-	21560	930
18"	914	930	914	2273	1803	-	28790	1300
20"	991	1010	991	2482	1955	-	34840	1625
24"	1143	1165	1143	3054	2425	-	51050	2800
26"	1245	1269	1245	3219	2540	-	62011	3100
28"	1346	1371	1346	3378	2641	-	73046	3600
30"	1397	1422	1397	3530	2743	-	84765	4200
32"	1524	1552	1524	3695	2857	-	100580	4850
36"	1727	1755	1727	3987	3048	-	125825	5900
40"	1955	1983	1955	4445	-	3713	171740	8100
42"	2032	-	2032	4699	-	3916	217000	9750
48"	2986	-	2986	5435	-	4501	326000	13050

Dimensions of larger sizes upon request.

## ■ Class 600

SIZE	FACE TO FACE (A)			H	L	K	CV	Approx. Weight RF (Kg.)
	RF	RTJ	BW					
2"	292	295	292	327	292	-	200	23
3"	356	358	356	609	533	-	710	85
4"	432	434	432	755	647	-	1300	120
6"	559	561	559	1073	914	-	3100	230
8"	660	663	660	1301	1092	-	5500	390
10"	787	790	787	1441	1181	-	8485	620
12"	838	841	838	1644	1333	-	12850	880
14"	889	892	889	1841	1473	-	15370	1350
16"	991	993	991	2070	1651	-	20170	1700
18"	1092	1095	1092	2184	1727	-	26200	2140
20"	1194	1200	1193	2540	2019	-	32100	2450
24"	1397	1406	1397	2755	-	2383	46750	4550
26"	1448	1460	1448	2921	-	2500	56300	5260
28"	1549	1562	1549	3136	-	2663	65900	5960
30"	1651	1664	1651	3327	-	2840	75520	6700
32"	1778	1794	1778	3581	-	3100	85180	8312
36"	2083	2098	2083	4013	-	3450	114250	10125
40"	2149	-	2149	4241	-	3600	156127	14300
42"	2260	-	2260	4322	-	3950	197272	16460
48"	2667	-	2667	5461	-	4600	296300	22900

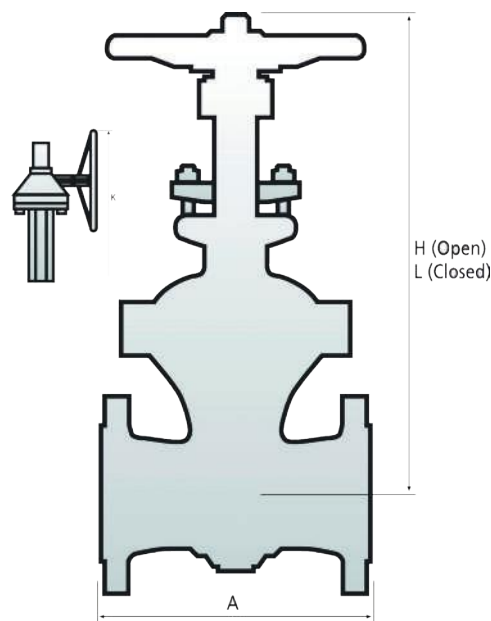

## ■ Class 900

SIZE	FACE TO FACE (A)			H	L	K	CV	Approx. Weight RF (Kg.)
	RF	RTJ	BW					
2"	368	371	368	468	433	-	155	70
3"	381	384	381	685	609	-	650	105
4"	457	460	457	774	673	-	1200	140
6"	610	612	610	1016	863	-	2850	300
8"	737	739	737	1282	1079	-	5025	530
10"	838	841	838	1485	1231	-	7850	950
12"	965	968	965	1682	1384	-	11500	1400
14"	1029	1038	1029	1924	1574	-	13900	1800
16"	1130	1140	1130	-	-	2159	18150	2400
18"	1219	1232	1219	-	-	2362	23910	3000
20"	1321	1333	1321	-	-	2463	29550	3800
24"	1549	1568	1549	-	-	3048	42570	4900
26"	1574	-	1574	-	-	3436	52167	6160
28"	1663	-	1663	-	-	3787	60500	7728
30"	1778	-	1778	-	-	4100	69452	10080
32"	1854	-	1854	-	-	4270	79092	12320
36"	2032	-	2032	-	-	4712	103212	15120

## ■ Class 1500

SIZE	FACE TO FACE (A)			H	L	K	CV	Approx. Weight RF (Kg.)
	RF	RTJ	BW					
2"	368	371	368	468	433	-	200	70
3"	470	472	470	781	711	-	600	130
4"	546	549	546	876	774	-	1070	200
6"	705	711	705	1104	965	-	2500	410
8"	832	841	832	1422	1244	-	4370	720
10"	991	1000	991	1784	1562	-	6850	1400
12"	1130	1146	1130	-	-	1955	9980	2500
14"	1257	1276	1257	-	-	2057	12000	3200
16"	1384	1406	1384	-	-	2311	15675	3800
18"	1537	1559	1537	-	-	2438	20640	4400
20"	1664	1686	1664	-	-	2590	25880	5200
24"	1943	1971	1943	-	-	2946	31175	9500
26"	3032	-	3032	-	-	3253	45514	10235
28"	2209	-	2209	-	-	3573	53320	11500
30"	2286	-	2286	-	-	3933	61095	15525
32"	2413	-	2413	-	-	4313	73478	18400
36"	2565	-	2565	-	-	4705	96862	21735

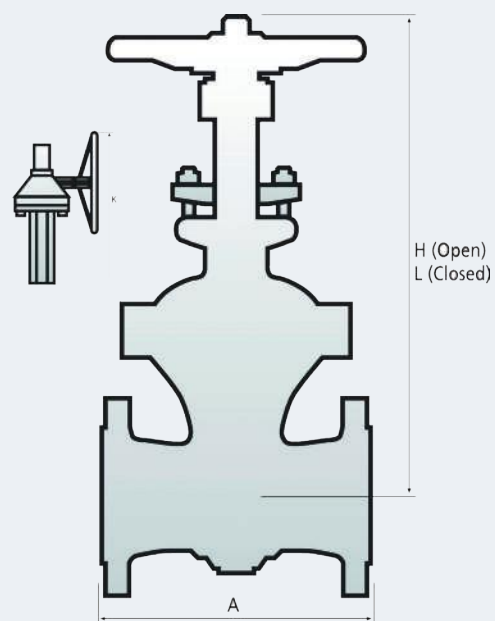

## ■ Class 2500

SIZE	FACE TO FACE (A)			H	L	K	CV	Approx. Weight RF (Kg.)
	RF	RTJ	BW					
2"	451	454	451	460	425	-	164	80
3"	578	584	578	696	625	-	275	275
4"	673	683	673	819	733	-	460	460
6"	914	927	914	1000	877	-	1100	1100
8"	1022	1038	1022	-	-	1567	1970	1970
10"	1270	1292	1270	-	-	1680	3130	3130
12"	1422	1444	1422	-	-	1840	4535	4535
14"	1526	-	1526	-	-	1974	8368	5500
16"	1699	-	1699	-	-	2080	10955	7210
18"	1908	-	1908	-	-	2214	14481	9415
20"	2012	-	2012	-	-	2427	17587	11450
24"	2220	-	2220	-	-	2672	21338	16575



## 07. GLOBE VALVE DIMENSIONS ANSI B16.34, BS 1873

### ■ Class 150

SIZE	FACE TO FACE (A)			H	L	K	CV	Approx. Weight RF (Kg.)
	RF	RTJ	BW					
2"	203	216	203	320	285	-	38,3	18
3"	241	254	241	400	355	-	100	36
4"	292	305	292	457	406	-	185	55
6"	406	419	406	609	546	-	440	104
8"	495	508	495	698	622	-	810	200
10"	622	635	622	762	685	-	1260	300
12"	698	711	698	876	774	-	1890	390
14"	787	800	787	990	889	-	2441	610
16"	914	927	914	1104	977	-	3234	880
18"	978	991	978	1206	1066	-	4308	1150
20"	978	991	978	1270	1117	-	5364	1650
24"	1295	1308	1295	1498	1295	-	7825	2200
26"	1295	-	1295	-	-	1560	9857	2545
28"	1448	-	1448	-	-	1680	11480	2887
30"	1524	-	1524	-	-	1800	13228	3712
32"	1626	-	1626	-	-	1920	15098	4262
36"	1956	-	1956	-	-	2160	19211	5431

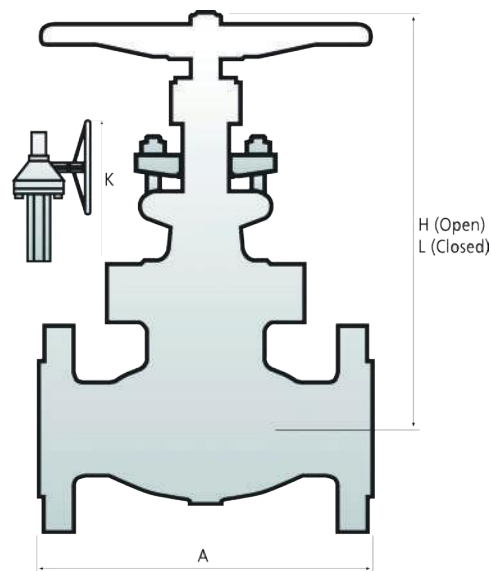

### ■ Class 300

SIZE	FACE TO FACE (A)			H	L	K	CV	Approx. Weight RF (Kg.)
	RF	RTJ	BW					
2"	267	283	267	350	315	-	38,3	26
3"	318	333	318	450	406	-	100	52
4"	356	371	356	584	533	-	185	88
6"	444	460	444	660	584	-	440	160
8"	559	574	559	762	673	-	810	259
10"	622	638	622	850	762	-	1260	420
12"	711	727	711	1187	1092	-	1890	595
14"	838	854	838	1085	990	-	2441	876
16"	863	879	863	-	-	1371	3234	1200
18"	977	994	977	-	-	1473	4183	1600
20"	1016	1035	1016	-	-	1574	5226	2100
24"	1346	1368	1346	-	-	1803	7657	3150
26"	1397	1422	1397	-	-	1950	9663	3720
28"	1524	1549	1524	-	-	2048	11271	4320
30"	1626	1651	1626	-	-	2140	13002	5040
32"	1727	1755	1727	-	-	2240	14858	5820
36"	2083	2111	2083	-	-	2416	18940	7080

Dimensions of larger sizes upon request.

## ■ Class 600

SIZE	FACE TO FACE (A)			H	L	K	CV	Approx. Weight RF (Kg.)
	RF	RTJ	BW					
2"	292	295	292	350	315	-	38,3	28
3"	356	358	356	546	508	-	100	93
4"	432	433	432	711	635	-	185	160
6"	559	561	559	965	914	-	440	310
8"	660	663	660	1117	1016	-	780	560
10"	787	790	787	1320	1219	-	1200	875
12"	838	841	838	-	-	1570	1810	1350
14"	889	892	889	-	-	2025	2356	2025
16"	991	994	991	-	-	2277	3094	2550
18"	1092	1095	1092	-	-	2402	4030	3210
20"	1194	1200	1194	-	-	2794	4930	3675
24"	1397	1407	1397	-	-	3030	7164	6825

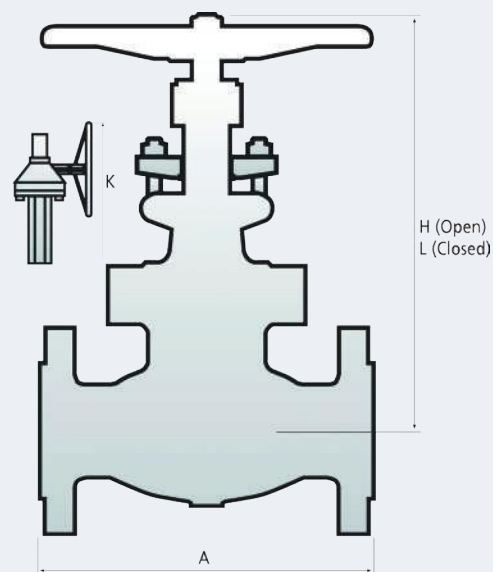

## ■ Class 900

SIZE	FACE TO FACE (A)			H	L	K	CV	Approx. Weight RF (Kg.)
	RF	RTJ	BW					
2"	368	371	368	420	385	-	24	55
3"	381	384	381	685	635	-	90	120
4"	457	460	457	838	774	-	170	200
6"	610	612	610	1117	1041	-	400	410
8"	737	739	737	1422	1333	-	710	790
10"	838	741	838	-	-	1625	1100	1400
12"	965	968	965	-	-	1850	1758	1912
14"	1029	1039	1029	-	-	2116	2134	2625
16"	1130	1140	1130	-	-	2375	2787	3300
18"	1219	1232	1219	-	-	2598	3672	4050
20"	1321	1334	1321	-	-	2709	4533	4950
24"	1549	1568	1549	-	-	3353	6528	6336

## ■ Class 1500

SIZE	FACE TO FACE (A)			H	L	K	CV	Approx. Weight RF (Kg.)
	RF	RTJ	BW					
2"	368	371	368	420	385	-	24	55
3"	470	473	470	685	635	-	95	122
4"	546	549	546	812	736	-	170	200
6"	705	710	705	1193	1092	-	395	623
8"	832	840	832	-	-	1482	695	1030
10"	991	1000	991	-	-	1482	695	1690
12"	1130	1146	1130	-	-	2150	1529	2730
14"	1257	1276	1257	-	-	2263	1838	3510
16"	1384	1406	1384	-	-	2542	2403	4420
18"	1537	1569	1537	-	-	2682	3164	5330
20"	1664	1686	1664	-	-	2849	3966	6500
24"	1943	1971	1943	-	-	3240	5698	8840

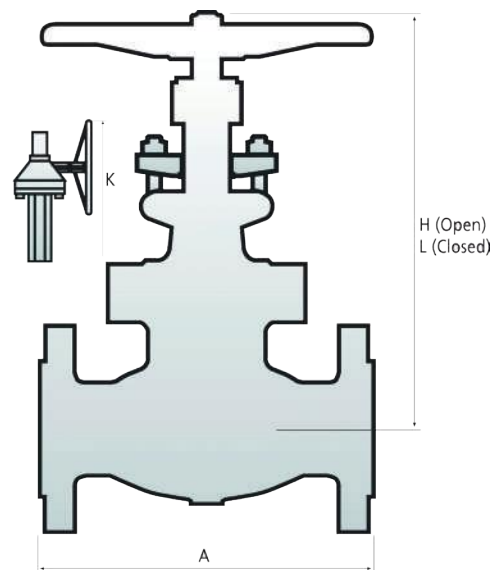

## ■ Class 2500

SIZE	FACE TO FACE (A)			H	L	K	CV	Approx. Weight RF (Kg.)
	RF	RTJ	BW					
2"	451	454	451	480	445	-	16	75
3"	578	584	578	671	642	-	61	118
4"	673	683	673	788	825	-	102	288
6"	914	927	914	1080	1136	-	253	813
8"	1022	1038	1022	-	-	1577	453	1375
10"	1270	1292	1270	-	-	1810	720	2375
12"	1422	1444	1422	-	-	2045	1057	3500
14"	1574	-	1574	-	-	2160	1283	4625
16"	1726	-	1726	-	-	2278	1680	6000
18"	1878	-	1878	-	-	2424	2221	7500
20"	2030	-	2030	-	-	2658	2698	9375
24"	2182	-	2182	-	-	2871	3909	13250

## 08. CHECK VALVE DIMENSIONS ANSI B16.34, BS 1868, API 6D

### ■ Class 150

SIZE	FACE TO FACE (A)			H	CV	Approx. Weight RF (Kg.)
	RF	RTJ	BW			
2"	203	216	203	140	101	15
3"	241	254	241	152	285	29
4"	292	305	292	190	520	40
6"	356	368	356	228	1245	78
8"	495	508	495	292	2280	140
10"	622	635	622	304	3570	215
12"	698	711	698	342	5300	295
14"	787	800	787	406	6500	408
16"	864	876	864	508	8615	533
18"	978	990	978	584	11500	670
20"	978	990	978	622	14300	1000
24"	1295	1308	1295	711	20865	1950
26"	1295	1308	1295	762	25165	2300
28"	1448	1460	1448	838	29513	2500
30"	1524	1537	1524	889	33910	2600
32"	1727	1740	1727	1016	43130	2800
36"	1956	1968	1956	1092	61570	3200
40"	2159	-	2159	1162	82934	4100
42"	2159	-	2159	1219	112960	4400
48"	2540	-	2540	1320	173000	5250

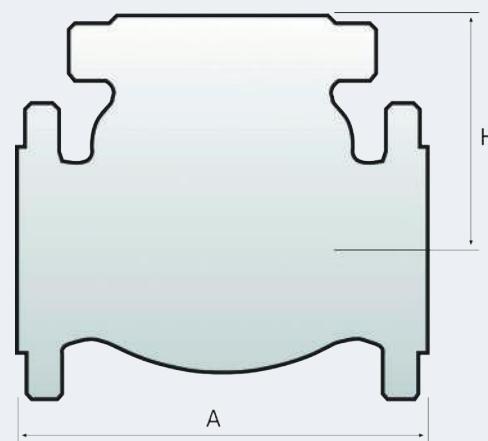

### ■ Class 300

SIZE	FACE TO FACE (A)			H	CV	Approx. Weight RF (Kg.)
	RF	RTJ	BW			
2"	267	282	267	145	101	19
3"	318	333	318	203	285	45
4"	356	371	356	228	515	65
6"	444	460	444	279	1245	115
8"	533	549	533	342	2285	215
10"	622	638	622	381	3575	310
12"	711	727	711	431	5345	470
14"	838	854	838	482	6510	550
16"	864	879	864	508	8620	870
18"	978	923	978	584	11155	1025
20"	1016	1035	1016	660	13935	1500
24"	1346	1368	1346	762	20420	2500
26"	1346	1371	1346	762	25000	2800
28"	1499	1524	1499	889	28750	3000
30"	1594	1619	1594	977	33910	3400
32"	1727	1755	1727	1016	42230	3700
36"	2083	2111	2083	1143	61570	4300
40"	2159	-	2159	1244	82210	5800
42"	2159	-	2159	1270	111350	6950
48"	2667	-	2667	1422	171500	8100

### ■ Class 600

SIZE	FACE TO FACE (A)			H	CV	Approx. Weight RF (Kg.)
	RF	RTJ	BW			
2"	292	295	292	145	101	20
3"	356	359	356	203	285	48
4"	432	435	432	228	520	67
6"	559	562	559	304	1245	110
8"	660	663	660	406	2210	205
10"	787	790	787	469	3400	325
12"	838	841	838	533	5120	480
14"	889	892	889	609	6150	600
16"	991	994	991	660	8070	800
18"	1092	1092	1092	774	10510	1490
20"	1194	1200	1194	889	12855	1675
24"	1397	1406	1397	965	18680	2300
26"	1448	1460	1448	1016	24600	2710
28"	1600	1612	1600	1066	29950	3125
30"	1651	1666	1651	1168	34680	3710
36"	2083	2098	2083	1320	45308	5800



## ■ Class 900

SIZE	FACE TO FACE (A)			H	CV	Approx. Weight RF (Kg.)
	RF	RTJ	BW			
2"	368	381	368	170	101	43
3"	381	384	381	304	26	90
4"	457	460	457	335	485	100
6"	610	612	610	442	1140	245
8"	737	739	737	472	2010	425
10"	838	841	838	548	3140	675
12"	965	968	965	700	4590	900
14"	1029	1038	1029	731	5565	1125
16"	1130	1140	1130	822	7270	1600
18"	1219	1232	1219	883	9575	2000
20"	1321	1333	1321	914	11820	2700
24"	1549	1568	1549	1067	17020	4100
26"	1701	-	1701	1219	20866	5100
28"	1828	-	1828	1279	24200	5750
30"	2032	-	2032	1402	27780	6510
36"	2562	-	2562	1625	41285	10180

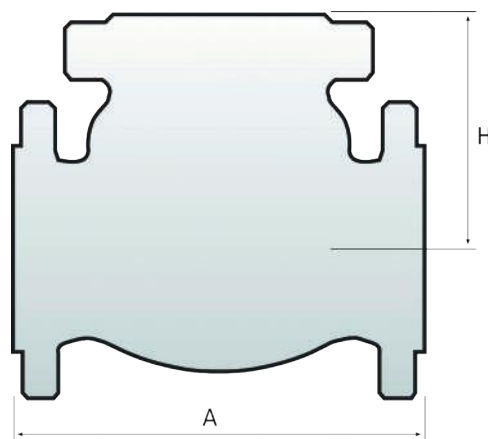

## ■ Class 1500

SIZE	FACE TO FACE (A)			H	CV	Approx. Weight RF (Kg.)
	RF	RTJ	BW			
2"	368	381	368	170	76	43
3"	470	483	470	305	240	70
4"	546	559	546	335	425	115
6"	705	711	705	442	1000	250
8"	832	855	832	578	1750	470
10"	991	1001	991	701	2735	800
12"	1130	1142	1130	701	3990	1350
14"	1257	1276	1257	792	4800	1800
16"	1384	1406	1384	822	6265	2200
18"	1537	1559	1537	914	8255	2600
20"	1664	1686	1664	1005	10350	3400
24"	1943	1971	1943	1158	14865	5160
28"	1956	-	1956	1356	21328	6900
30"	2057	-	2057	1417	24438	9000
36"	2594	-	2594	1644	36285	14070

## ■ Class 2500

TAMA- NÖ	FACE TO FACE (A)			H	CV	Approx. Weight RF (Kg.)
	RF	RTJ	BW			
2"	451	464	451	170	48	58
3"	578	584	578	305	115	120
4"	673	683	673	335	195	220
6"	914	927	914	442	475	540
8"	1022	1038	1022	640	850	920
10"	1270	1292	1270	762	1350	1629
12"	1422	1444	1422	822	1970	2296
14"	1519	-	1519	883	3638	3000
16"	1691	-	1691	944	4763	3776
18"	1900	-	1900	974	6050	4692
20"	1900	-	1900	1036	7348	5500
24"	2438	-	2438	1220	10646	7000

## 09. GATE API 6A VALVE DIMENSIONS

### ■ API 2000

SIZE	A	H	B	CV	Approx. Weight RF (Kg.)
2 1/16"	295	488	122	413	54
2 9/16"	333	512	142	655	81
3 1/8"	359	571	176	974	99
4 1/16"	435	658	219	1693	163
5 1/8"	562	825	295	2778	362
7 1/16" x 6 3/8"	562	825	295	4593	362
7 1/16"	664	840	352	5446	463

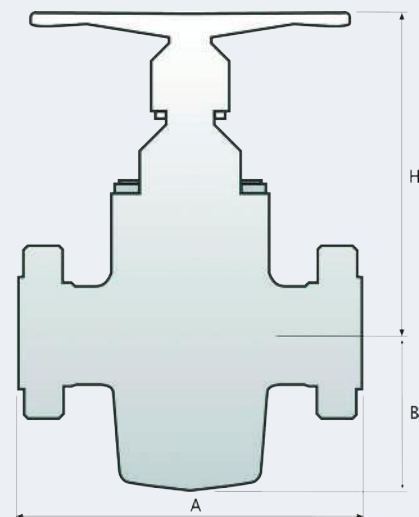

### ■ API 3000

SIZE	A	H	B	CV	Approx. Weight RF (Kg.)
2 1/16"	371	493	128	413	56
2 9/16"	422	519	150	655	99
3 1/8"	435	577	185	974	136
4 1/16"	511	669	230	1693	235
5 1/8"	613	825	295	2778	408
7 1/16" x 6 3/8"	613	825	295	4593	408
7 1/16"	714	866	352	5446	507

### ■ API 10000

SIZE	A	H	B	CV	Approx. Weight RF (Kg.)
1 13/16"	464	418	144	318	108
2 1/16"	521	417	144	413	120
2 9/16"	565	448	171	655	167
3 1/16"	619	471	206	974	235
4 1/16"	670	544	258	1693	385
5 1/8"	737	612	295	2776	855
7 1/16" x 6 3/8"	889	756	373	4593	1095
7 1/16"	889	756	373	5446	1095

### ■ API 5000

SIZE	A	H	B	CV	Approx. Weight RF (Kg.)
2 1/16"	371	493	128	413	56
2 9/16"	422	519	150	655	99
3 1/8"	473	577	185	974	154
4 1/16"	549	669	230	1693	254
5 1/8"	727	825	295	2778	444
7 1/16" x 6 3/8"	737	836	300	4593	540
7 1/16"	813	866	352	5446	634
9"	1041	1108	424	9154	810

### ■ API 15000

SIZE	A	H	B	CV	Approx. Weight RF (Kg.)
1 13/16"	457	425	149	318	136
2 1/16"	483	425	149	413	149
2 9/16"	533	481	196	655	204
3 1/16"	598	578	245	974	235
4 1/16"	737	636	297	1692	616
5 1/8"	889	755	365	2776	1368

## 10. CHECK API 6A VALVE DIMENSIONS

### ■ API 2000

SIZE	A	H	CV	Approx. Weight RF (Kg.)
2 1/16"	295	168	129	20
2 9/16"	333	241	205	42
3 1/8"	359	206	295	35
4 1/16"	435	206	526	67
7 1/16"	562	267	1182	136
9"	664	315	2895	248

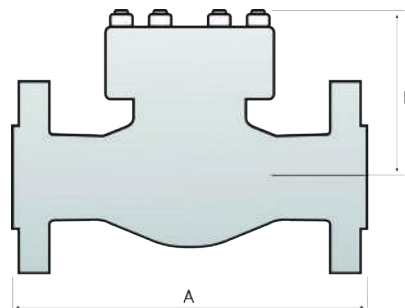

### ■ API 3000

SIZE	A	H	CV	Approx. Weight RF (Kg.)
2 1/16"	371	181	115	32
2 9/16"	422	245	170	45
3 1/8"	384	229	265	48
4 1/16"	460	229	473	95
7 1/16"	613	290	1182	198
9"	740	350	2895	356

### ■ API 5000

SIZE	A	H	CV	Approx. Weight RF (Kg.)
2 1/16"	371	190	87	40
2 9/16"	422	241	142	61
3 1/8"	473	241	216	100
4 1/16"	549	311	393	160
7 1/16"	711	394	926	232
9"	841	466	2895	443

### ■ API 10000

SIZE	A	H	CV	Approx. Weight RF (Kg.)
1 13/16"	464	238	100	40
2 1/16"	521	267	87	71
2 9/16"	565	362	142	106
3 1/16"	619	362	216	175
4 1/16"	670	467	393	280
5 1/8"	737	490	949	332
7 1/16"	889	591	926	406

### ■ API 15000

SIZE	A	H	CV	Approx. Weight RF (Kg.)
1 13/16"	457	247	100	50
2 1/16"	483	261	87	90
2 9/16"	533	353	142	137
3 1/16"	598	353	216	225
4 1/16"	737	456	393	360

# 11. MANUFACTURING RANGE

## ■ Gate

Standards	Sizes	Features Design - Materials	
ANSI B16.34 API 600 API 6D BS - 1414	- 72" ANSI 150 - 64" ANSI 300 - 48" ANSI 600/900 - 36" ANSI 1500/2500 - 24" ANSI 4500	Bolted bonnet Pressure seal Cast and forged Solid Wedge Flexible	
API 6A	2-1/16" to 7-1/16" class 2000 2-1/16" to 7-1/16" class 3000 2-1/16" to 9" class 5000 1-13/16" to 7-1/16" class 10000 1-13/16" to 5-1/8" class 15000	Split Wedge Parallel Slide Through conduit Special Designs Double Block and Bleed	

## ■ Globe

Standards	Sizes	Features Design - Materials	
ANSI B16-34 BS-1873	- 48" ANSI 150/300 - 36" ANSI 600/900 - 24" ANSI 1500/2500 - 12" ANSI 4500	Bolted Bonnet Pressure seal Cast and forged Zero stem leakage Non return "Y" pattern globe Bellows seal globe Stop check globe Angle globe valve	

## ■ Control

Standards	Sizes	Features Design - Materials	
ANSI B16.34	- 16" ANSI 150/2500 - 4" ANSI 4500	Cage guided globe Top guided globe Angle type 3 - Way type Butterfly type	



## ■ Check

Standards	Sizes	Features Design - Materials	
API 6D BS-1868 ANSI B16-34	- 64" ANSI 150 / 300 - 48" ANSI 600/900 - 36" ANSI 1500/2500 - 24" ANSI 4500	Bolted bonnet Pressure seal Cast and forged Piston check	
API 6A	2-1/16" to 11" class 2000 2-1/16" to 11" class - 3000 2-1/16" to 11" class - 5000 1-13/16" to 7-1/16" class 10000 1-13/16" to 4-1/16" class 15000	Tilting disc Swing check Emergency assisted Duo Check	

## ■ Ball

Standards	Sizes	Features Design - Materials	
API 6D	- 56" ANSI 150 to 900 - 36" ANSI 1500 / 2500	Floating type Trunnion mounted	
API 6A	2-1/16" to 7-1/16" class 2000 2-1/16" to 7-1/16" class 3000 2-1/16" to 9" class 5000 1-13/16" to 7-1/16" class 10000 1-13/16" to 5-1/8" class 15000	Top Entry and Side Entry design 3-Way Metal to Metal or Soft Seated Bolted or fully welded design 2-piece and 3-piece design	

## ■ Butterfly

Standards	Sizes	Features Design - Materials	
AWWA C-504	40" - 120" CLASS 25 A up to 250 A	Rubber lined Check Butterfly Single piece disc	
BS - 3952	3" - 40" ANSI 250		

## ■ Choke

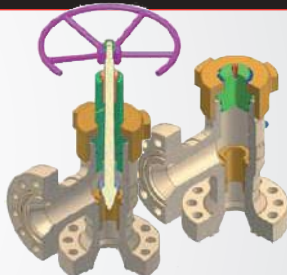
Standards	Sizes	Features Design - Materials	
API 6A	2-1/16" - 7-1/16" - 2000 2-1/16" - 7-1/16" - 3000 1-13/16" - 7-1/16" - 5000 1-13/16" - 7-1/16" - 10000	Positive Adjustable	

Unit 6, Floor 1, No 16, North Isargaran St, Yadegar-e Emam Expy, Tehran, Iran. Tel: +98 21 2214 70 61-3  
E-mail: [Info@Notashsanat.com](mailto:Info@Notashsanat.com) [www.Notashsanat.com](http://www.Notashsanat.com)